



Control Units MAGTRONIC

Loop Detector MID 1 E - 800

Technical data	Type
Power supply :	V
Power consumption:	W
Operating temperature:	
Humidity	
Loop inductivity:	
Frequency range:	
Sensitivity (df / f):	
Loop lead length:	
Relays:	
Switch voltage:	
Housing	
Dimensions: (h x w x d)	mm
Protection	

MID 1E	
Power supply	24 V AC/DC, +/- 10%
Power consumption	max. 1.5 W
Operating temperature	-20 ° – +70° C°
Humidity	max. 95%
Loop inductivity	25 – 800 uH
Frequency range	30 – 130 kHz
Sensitivity (df / f)	0.01% – 0.65%
Loop lead length	max. 250 m
Relays	1 presence relay 1 pulse relay
Switch voltage	24 V AC/DC
Housing	plastic housing for C-rail with 2x 3-pin. clamps
Dimensions: (h x w x d)	79 x 22.5 x 90 mm
Protection	IP 40

The MID Detektor

The microprocessor-controlled, single channel MID detector can detect vehicles without contact. Via the connected induction loop all sorts of metallic vehicles like cars, trucks, buses, fork lifts and even bicycles are easily detected.





Applications:

- barrier controls
- parking and traffic technology
- door and gate controls

Setting options

Sensitivity



The setting of the sensitivity is adjustable and gives the frequency deviation which a vehicle must produce for setting the output of the detector. The sensitivity can be adjusted in 4 steps with the two DIP-switches s on top of the front panel.

sensitivity step	DIP-switch s
1 low (0,64% f/F)	
2 (0,16% f/F)	
3 (0,04% f/F)	
4 high (0,01% f/F)	

Hold time and Reset

The hold time can be adjusted with DIP-switch h.

At the completion of the hold time it will be displayed "free loop" and the detector calibrates automatically. The hold time starts with the occupation of the loop.



hold time	DIP-switch h
5 minutes	
infinite	

An automatic calibration of the loop frequency will be done by the detector after switch-on of the power supply. In case of short power cuts < 0,1 s there is no calibration.

A reset with calibration can be effected by changing the hold time setting.

Operation principle of the presence relay

The detector has one relay for presence output and another relay for pulse output each with a potential free contact. The operation principle of the presence relay can be changed with the DIP-switch r.

operation principle presence relay	DIP-switch r
contact normally closed	
contact normally open	

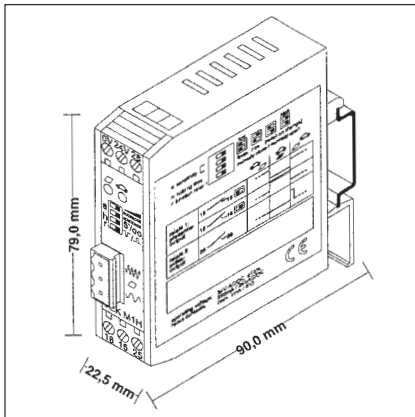

Frequency adjustment

The operation frequency of the detector can be adjusted in two steps by the 3-pole connection jack in the front panel. The permissible frequency range is 30 kHz to 130 kHz. The frequency depends on the loop inductivity (depending itself on: loop geometry, number of loop turns and loop lead) and the adjusted frequency step.



Outputs and LED Contact mode of the relays

The following table shows the state of the relay contacts depending on the detector mode.

detector mode	presence relay		pulse relay
			
free loop	closed	open	open
covered loop	open	closed	open
loop gets free	closed	open	200 ms pulse
loop failure	open	closed	open
power off	closed	closed	open

Output of the loop frequency

Approx. 1 s after calibration of the detector the loop frequency will be displayed by pulse signals of the green LED. Firstly the 10 kHz position of the frequency value will be indicated. For every 10kHz frequency value the green LED flashes once. After a break of 1 sec the 1 kHz position is displayed in the same manner. If there is value of 'O' in the 1 kHz position there will be displayed 10 flashes. The flashes of the 1 kHz position are a little bit shorter than for the 10 kHz position.

In case of a loop failure the detector checks the loop condition cyclically and continues after elimination.

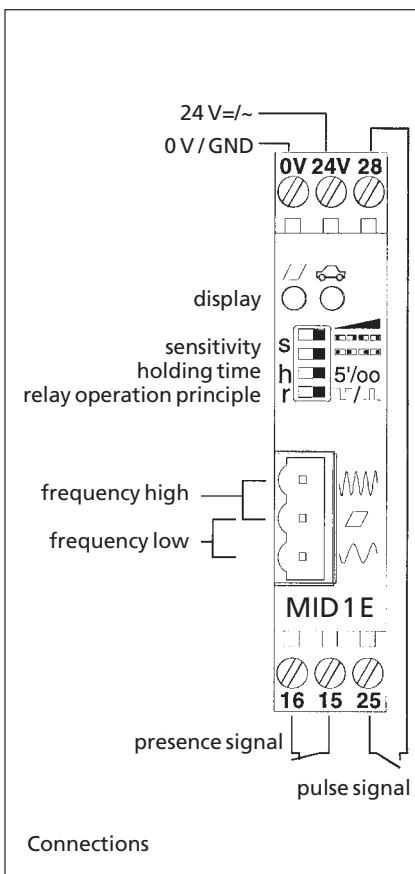

LED-signals

The green LED signals that the detector is ready for operation. Via the red LED, the activation of the relays output is announced depending on the occupation status of the loop.